



# Wet Gas Metering / Sampling

New Method to Determine the Liquid Content of a Wet Gas Stream and Provide a Sample of the Liquid Phase for Compositional Analysis.

By Mark A. Jiskoot, Jiskoot and Ken Payne, AMEC.

A paper presented at the North Sea Flow Measurement Workshop, 2003 - Updated June 2004

## Summary

There is currently no other method available that is capable of accurate measurement of the liquid mass of a wet gas stream. Jiskoot has, in conjunction with AMEC, developed a wet gas sampling methodology that can determine the liquid/gas mass ratio as well as providing a compositional sample to allow laboratory determination of the chemical composition of condensates, methanol and water.

## Introduction

The measurement of multiphase flow regimes is not simple, recent work by the industry has concentrated on the measurement of wet gas recognising that a significant value may be associated with the liquids. (Depending of course on what the liquids are!) A variety of methods have been used including dye tracer and microwave, this wet gas sampler development was initiated because other techniques could not provide the required data set in the given process.

Metering wet gas using a differential pressure based element such as a Venturi, the output over-meters due to the presence of liquids. To compensate for this and therefore to reduce the uncertainty, it is necessary to adjust the metered rate for the liquid/gas mass ratio. The industry has generally accepted the use of Murdoch-Chisholm or DeLeeuw equations. In this project the remit was to seek an overall uncertainty of better than 2.5 % by mass.

## The Project Outline

The provisional data set was that the GVF was in the range 98 to 99 % by mass at 80 bar (higher by volume) and that no slugging was expected.

Component	Percent Mass	Percent Volume
Gas	98.14	99.79
Condensate	0.30	0.02
Water	1.30	0.16
Methanol	0.26	0.03

Figure 1 - Wet gas ratio by mass volume

There is currently no available multiphase metering technology that will determine liquid mass ratio and composition.

The use of a variety of methods was investigated, including microwave, dye tracer, centrifugal separation and a gas scrubber, but these were discounted. The dye tracer due to the inability to trace methanol and lack of available distance (to allow the tracer to bond to the liquids). The microwave techniques can only measure water content (and then with a high degree of uncertainty) requiring a process (inc PVT) model for other fluids and the gas scrubber was discounted due to lack of an available drive mechanism for the volumes of gas required and the inability to discriminate the methanol/water. This led to the decision to choose an off-line method based upon sampling.

## Data set

The desired data set to be achieved is the liquid mass ratio and the composition of both the liquid and gas phases.

In considering these requirements it is obvious that a dry gas composition can be achieved with a spot sample taken from a simple hot tap on the pipe, but to achieve an overall sample of “wet gas” requires a number of further steps.

The first step to be achieved is to try and create an even distribution and dispersion of the liquids within the gas stream. At the projected conditions, a mist flow regime is expected. There are several papers that suggest that a wall or annular liquid flow can be re-entrained downstream of an expansion so to optimise dispersion quality. The project team decided to install the sampling system at a position downstream of the metering Venturi.

The second step in the sampling chain (or the first “physical” point) is the sample offtake. A multipoint offtake was chosen to further average any distribution or dispersion variances.

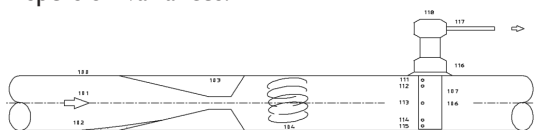

Figure 2 - Wet gas sampling system concept

This was to be a spot sampling methodology, it was considered important to maintain in so far as possible the properties of the process stream and to vent gas through the system during the sample process. This renders possible simple control over flowrates, velocity etc. during the life of the field.

## Design Considerations

In this application every litre of gas at process conditions has 0.2ml of Condensate, 1.6ml of Water and 0.3ml of



Figure 3 - 2 litre constant pressure sample receiver

Methanol. A typical sample cylinder to take a 1 litre sample of gas weighs 15 Kg and the 2.1ml of liquid collected within would easily be lost on the walls, in the seals or interconnecting tube and fittings.

Even if the cylinder could collect the liquids, how would the mass be accurately discriminated? The accuracy of a mass balance suitable for 15Kg would have a resolution of 0.5 to 1g, which would render any uncertainty in the liquid mass ratio as meaningless. Increasing the overall volume to attain a larger incremental mass is self defeating (larger cylinder mass) so the project concentrated on increasing the mass resolution by collection of more fluids that could be filtered out from a known mass of gas and taking a separate dry gas sample.

A variety of techniques were considered including silica gel or benzene traps but ultimately a mole sieve (Zeolite) was selected on the basis that this method is already in common use for scrubbing gas.

The basic principal selected for the sampling system is to flow a representative stream of gas through a mole sieve and a mass flowmeter at process conditions, reducing pressure downstream to vent. Provided that the mole sieve can collect the liquids and that the flowmeter can record the total mass of gas, then by weighing the mass increase of the mole sieve, the total liquids mass for a given mass of gas can be established.

## Sources of uncertainty

Ignoring, for the time being, the sample offtake system, the uncertainties in the sampling methodology can be broken into several areas.

### Determination of the mass ratio

- Depends on the ability of the mole sieve to collect and retain the liquids.
- The resolution of the recording of the mole sieve mass increase and the gas mass flowmeter.

### Determination of the composition

- Depends on the ability to recover and analyse the liquids collected.

It was assumed that if a representative sample could be collected, then the sample could be analysed.

### Determination of the liquid mass ratio

The mole sieve comprises a cylinder packed with Zeolites which are crystalline, highly porous, materials with a three dimensional structure having pores of predictable sizes.

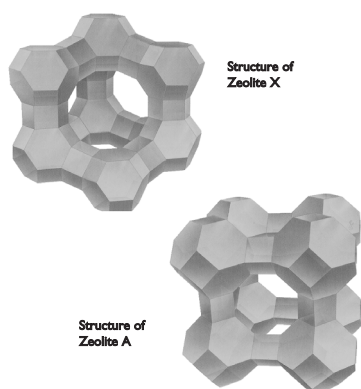

Figure 4 - Zeolite structure

The pores have an affinity to sieve out polar molecules that fit within their structure.

They are manufactured in a range of pore sizes, typically 3, 4, 5 and 8 Angstrom although there is a variation in the way manufacturers express the

sizing. (Zeolite 13X is 8 Angstrom) Generally a molecule larger than the structure of the Zeolite will not be trapped, a typical example of some sizes are shown below.

Component	Percent Mass	Percent Volume
Inorganic	Water	2.6
S-Compounds	Hydrogen	3.6
	Methyl Mercaptan	3.8
Paraffins	Methane	3.8
	Ethane	4.2
	n-Butane	5.1
Aromatics	Benzene	5.8
Alcohols	Methanol	3.6
	Ethanol	4.2

Figure 5 - Typical molecule size

Given a choice of molecules to adsorb, there is also a known hierarchy with reference to our particular process interest. The hierarchy is such that the most polar molecules are adsorbed first.

In our case these are: Water, Methanol, Ethanol

The hydrocarbons will take the order of the alkenes (the greater the unsaturation the more strongly adsorbed) followed by the alkanes. With each of these series the higher molecular weight member will be adsorbed first. i.e. C8's before C1's. There will be some cross over between the two series, i.e. Ethene before Propane.

Zeolites will adsorb about 20% at best by mass and

during the process generate heat (Exothermic reaction), the adsorption process is reversible using a variety of techniques.

Adsorption is clearly not "instant" so consideration was given to the velocity through the column (residence time), contact area (bead size) and the mass of liquid required to provide reasonable uncertainty.

The issue also to be determined was a reasonable time for the sample process during which a dry gas sample could be taken. As always this is a compromise based upon the expectation for the process and our initial choice was made trying to attain a mole sieve total mass below 2 kg. This provided an internal volume of about 250ml. We designed and constructed the system based upon provision of samples from each of two flow streams.



Figure 6 - 250ml molecular sieve

Initial testing focussed upon the ability of the sieve to extract the liquids from the gas stream at isokinetic flow velocities (as defined by the sample inlet configuration). This was performed using compressed air and water.

Recovery in the range 85 – 95% was experienced using factory supplied (out of the packing) sieve material. It proved difficult to get a stable baseline for the liquid content of the air stream despite the use of chillers and cooling coils. However these tests served to prove that the basic principle was valid.

During the first tests it became apparent that some basic performance for the sieve could be ascertained by locating the peak temperature of the exothermic reaction. At the highest flowrates this zone would spread and peak within 7 cm of the outlet whereas at low flowrates, it would be evident closer to the inlet.

To further enhance the performance it was determined that the diameter of the mole sieve be doubled (volume quadrupled) and that the column be packed with a mixture of 4 and 8 angstrom material at 4mm diameter. It was determined that this could still be achieved within

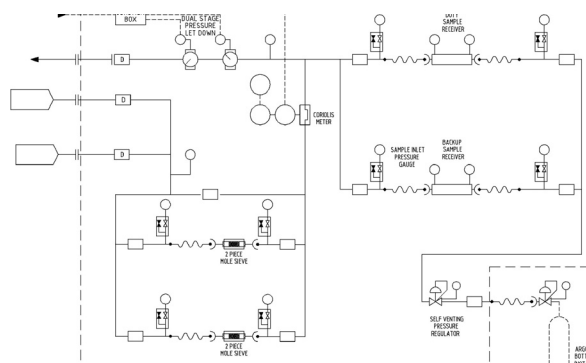

Figure 7 - Dual wet gas sampling systems

a fully loaded weight below 5 Kg and therefore measurable on a laboratory mass balance to a resolution of better than 0.1 gm.

With these design changes the system can trap in excess of 95% (under optimum conditions 100%, under the worst test of the \_ volume sieve 80%) of the liquids and measure the total mass to a resolution better than 0.1gm in a nominal 30-50gm liquid sample (0.20% – 0.33%). The resolution of the mass flowmeter used to record the total gas mass is 0.35%. The basic principle was therefore determined to have excellent potential.

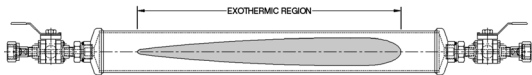

Figure 8 - Molecular sieve exothermic region

### Determination of the composition

Having established the basic design a second series of tests were performed on the collection and recovery of process fluids using the following set-up.

The original intent was that the liquids might be removed by vacuum extraction, it was quickly determined that NO liquids could be extracted under vacuum at room temperature! A limited number of tests were then conducted by heating the sieve to about 100oC with a little improvement. A simple test was performed to determine if the application of temperature would remove water from the mole sieve material, which it did so a new methodology was required for heating and extracting the liquids which in its final form is shown below.

Significant work has been undertaken on the laboratory process both in extraction and preconditioning the mole sieves and some further tuning of this and the selection of zeolites may be required, currently recovery rates in the order of 88 – 95% have been achieved. It is worth remembering that the primary objective was to ascertain the liquid mass ratio and therefore the recovery uncertainty is not relevant to the primary compensation of the metering result.

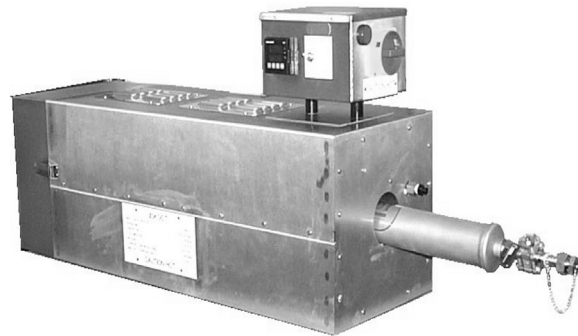

Figure 10 - Liquid recovery system

### Conclusion

A system and analysis process has been developed that will allow the determination of the liquid content and composition of a wet gas stream to an improved accuracy than previously, this process should be suitable for adoption to many applications for testing wet gas, it lends itself also to being used as a portable device.

*\*This wet gas sampling methodology has been patented.*

Slipstream Set-up for Contamination of MOL Sieve Cylinder

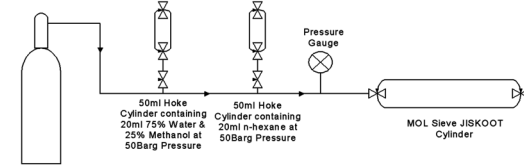

Removal of Water, Methanol & Condensate from Jiskoot MOL Sieve Cartridge

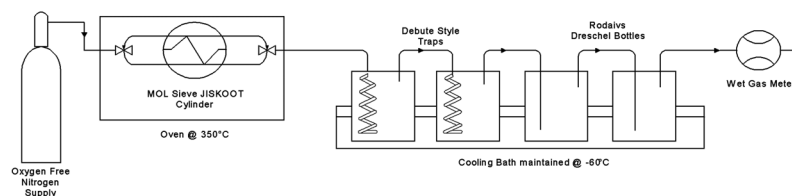

Figure 9 - Sample extraction process



**UK**  
Jiskoot Quality Systems

Tel: +44 (0)1892 518000  
Fax: +44 (0)1892 518100

Email: ms-jiskootuksales@c-a-m.com

**USA**  
Jiskoot Quality Systems

Tel: +1 281 583 0583  
Fax: +1 281 583 0587

Email: ms-jiskootusasales@c-a-m.com

**Cameron**  
Measurement Systems

Tel: +1 281 582 9500  
Fax: +1 281 582 9599

Email: ms-marketing@c-a-m.com

Jiskoot Quality Systems  
A Cameron Company  
[www.jiskoot.com](http://www.jiskoot.com)

