



# Jet Mixing

## A new approach to pipeline conditioning

by M.A. Jiskoot, A paper presented at Petro-Expo, Houston, Texas

### Introduction

Accurate sampling from a flowing pipeline requires that the point from which the sample is drawn is representative of the average (quality) of the whole cross section.

If the pipeline velocity is adequate the homogeneity of the cross section is assured by natural turbulence; these considerations are discussed in another paper (see ref. 1). Where natural turbulence is insufficient, the distribution may be improved by using in-line static mixers, motor driven shear mixers (similar to tank mixers) or alternatively jet mixers. Fig 1 details the comparative limitations of these solutions.

Where flowrate rangeability is high the Jet-Mix® system provides an ideal and energy efficient solution.

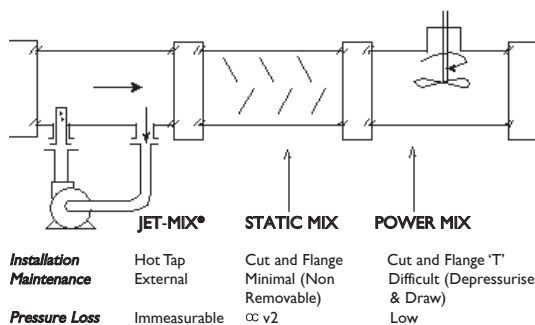

Figure 1. Comparison of Mixing Systems

### Brief guide to two-phase flow

To fully understand the design of the Jet-Mix®, a short introduction to pipeline flow is necessary.

Water and oil in a static tank will separate out due to their gravity difference; the rate of separation is a function of the gravity difference, the viscosity, the droplet size and a property called the inter-facial tension.

Gravity tends to make a water droplet fall while the drag slowing it down is determined by the weight to area ratio (see Fig. 2). The smaller the droplet size, the slower the fall rate. When droplets are so fine that they form emulsions (less than 10 micron diameter) the rate of separation is very slow and it may not be possible to determine water content by normal analysis methods.

In pipeline flow, sideways migration and shear of the fluid is always occurring. The degree of shearing increases with pipeline velocity, reducing droplet size and improving the overall dispersion and distribution.

Conversely, gravitational fallout and collision with other droplets promotes separation back into two separate phases.

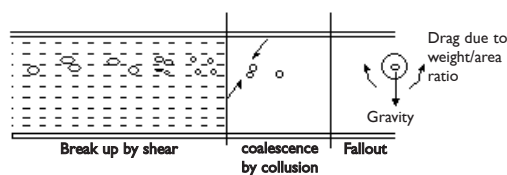

Figure 2. Droplet Break-up and Coalescence

**Jet Mixing**  
 A new approach to pipeline conditioning

### Development of the Jet-Mix®

The concept of applying jet mixers to pipeline conditioning was originated in 1978 with a pilot study using a 2" pipe with water as the main medium and plastic beads as the denser material (ref. 2). The beads were fed into the flowing stream and a single point jet from the bottom of the pipe was used to promote turbulence. The percentage of beads in the top and bottom of the pipe were recorded by weight to give an estimate of vertical distribution (see Fig. 3).

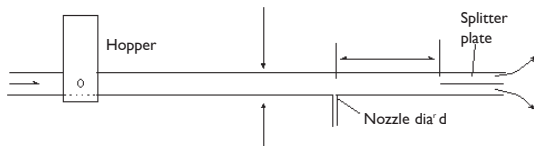

Figure 3. Pilot Study Rig

Further tests were performed using kerosene and water in a 4" line with different jet velocities, configurations and energy flowrates (refs. 3 & 4).

Finally, tests were performed on a 20" crude line to verify the scaling possibilities from the models (ref. 5). The results of these tests were used to determine the optimum design for a Jet-Mix® system.

### Principle of the Jet-Mix®

A Jet-Mix® system has two major components, the pump which provides the external energy source and the jet which re-injects the oil back into the pipe (see Fig. 4).

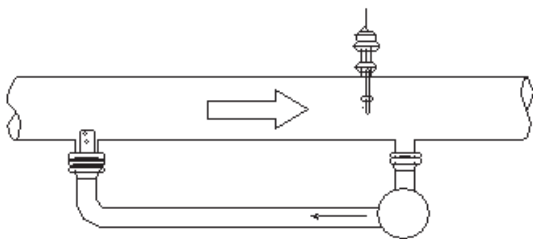

Figure 4. Jet-Mix® System

The basic principle of the Jet-Mix® is different from any other mixing system. Instead of generalised turbulence and shear of the whole fluid mass, the jet energy is concentrated locally to the break-up of slugs of water to a fine droplet size, requiring less energy to distribute. This is achieved by locating the area of maximum energy addition at the point where the concentration of water is highest (in the bottom of the pipe). The droplets are broken up and then re-distributed.

The jet design has two functions (see Fig. 5).

1. Break-up of large water globules into small droplets.
2. Distribution of the water droplets across the pipe cross section.

The jet assembly is normally mounted through the bottom of the pipe and acts on the area where the concentration of water is highest.

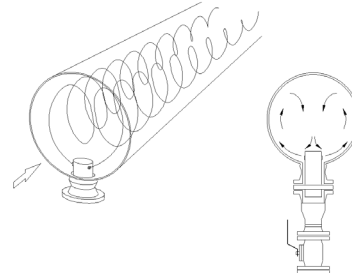

Figure 5. Jet Function

The lower of the two jets are close to the wall and angled on a tangent so as not to cause erosion, breaking up large water droplets into smaller droplets as well as rotating the contents of the pipeline. A forward facing jet splits the flow upstream of the mixer.

The upper jets assist in this rotation aiding the distribution by creating the twin cell helix rotation (Fig 5).

### Contrast between in-line static mixers and jet mixers

“Natural” mixing is worst at low flowrates (Fig. 6).

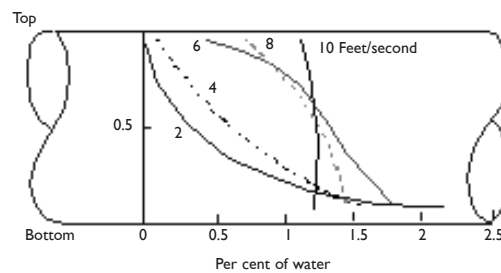

Figure 6. Concentration vs. Velocity in Horizontal Pipes

In-line mixers derive their energy from the line flow, turbulence is created by dividing and turning the fluid; energy added to the flow for mixing is generally proportional to the square of the flowrate.

The energy added to the flow by a Jet-Mix® is constant; considered in terms of mainline flow, the energy added per unit volume increases as the mainline flowrate drops (see Fig. 7).

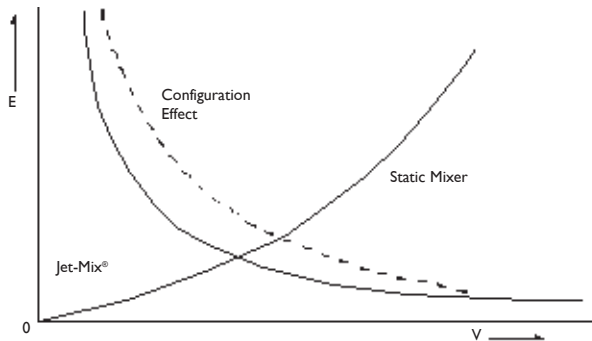

Figure 7. Energy added per Unit Volume vs. Line Velocity

The jet adds adequate energy for mixing, the system configuration further improves the mixing efficiency.

### Configuration of the Jet-Mix®

The suction for the loop is drawn from the bottom of the pipe in a nominally homogeneous zone downstream of the jet.

If the jet has not adequately mixed the pipe contents, the lower half of the pipe would contain a higher concentration of water. Some of this will be drawn back into the suction and passed through the system a second time. As the mainline flowrate drops, the percentage re-circulated increases. Typically at 1ft/sec. 20% - 30% of the contents are being passed back (passback ratio).

This passback represents a further increase in the energy added per unit volume.

Addition of a static mixer in the bypass loop can increase the system mixing performance. The static mixer ensures that any droplets reintroduced to the flow through the jet are so small that they may be adequately distributed by virtue of their size alone.

(Note: The static mixer in this application is working at a constant flowrate.)

Summary:

1. The jet energy is added to the area of highest water increasing the overall efficiency of the process.
2. The jet provides enough energy to mix irrespective of the system configuration.
3. The downstream suction will re-circulate the contents of the bottom of the pipe, providing a safety margin for the system.
4. The energy added per unit volume increases as the flowrate drops due to both constant energy addition and an increase in the re-circulation percentage.
5. Small droplet size engendered by a static mixer in the bypass can assist distribution for sampling.

### Component location

In determining the location of the jet, the suction and the probe, many considerations must be made. The single most important criteria is the location of the sample offtake (be it a probe or fast-loop system) in reference to the jet, this must be chosen to be in the “acceptably mixed” plateau between optimum energy transfer from the jet and re-separation into the two phases (see Fig. 8). The sample location must be optimised not for the lowest flowrates, but for intermediate flowrates where the length of the acceptable mixing plateau is shortest. If the sample is taken too close to the jet it would be possible to generate a higher concentration of water at the top of the pipe than at the bottom under some circumstances due to the “corkscrew” effect of the jet, i.e. the pipeline contents are poorly distributed.

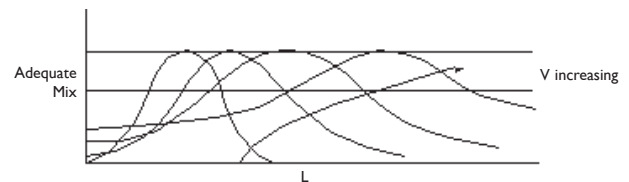

Figure 8. Jet-Mix® Residence Time

The suction should be located in a nominally homogeneous zone; too far downstream will increase the water concentration pumped and the pump HP requirements.

In many locations there is a restriction on the available pipe length and the probe is located between the jet and the pump suction. Questions of representivity arise. It has been shown (ref. 6) that the net error to the sample in the worst case is equivalent to the volume contained in the Jet-Mix® loop divided by the overall batch volume. The integration of a fast-loop sampling system with the Jet-Mix® system using a quill takeoff further reduces the pipe length required to install a mixer. (See Jiskoot Co-jetix)

### Testing

What criteria should be used to judge a mixing system? The API recommends a field test to prove the effectiveness of sampling and/or mixing systems. One of the items this proving test should verify is the adequate distribution and dispersion of free water at the sample point.

To test a location for adequate mixing, multi-point profiling is recommended, with the criteria that no point should deviate from the mean value by more than  $\pm 0.05\%$  for each 1% water. Figure 9 shows the results of

one such profiling exercise. If the location passes this criteria it may be adequate for sampling and this leads to the second test - "system proving". This is conducted by injecting a known quantity of water into a flowing crude oil pipeline, taking samples, analysing the samples for water and comparing the results with the quantity of water injected, plus the baseline water level in the crude. The total sampling system is tested and, if adequate, will meet the criteria for representative sampling.

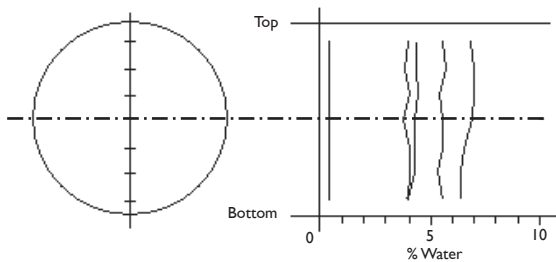

Figure 9. Multipoint Profile of a Jet Mixer on a 34" Line

### Summary

The Jet-Mix<sup>®</sup> provides an interesting, efficient and elegant solution to the problem of pipeline mixing. The problem with many mixer designs are under-mixing at low flowrates where it is most critical and over-mixing and energy wastage at high flowrates (i.e. rangeability). The Jet-Mix<sup>®</sup> has no problems with under-mixing at any rate, care must be taken to ensure that it does not over-mix at low flowrates. It can be turned off at high flowrates to conserve energy if it is not required.

The Jet-Mix<sup>®</sup> can also be installed without depressurising and draining the pipeline and can be removed for pigging which has made it the only technology suitable for many marine applications.

The Jet-Mix<sup>®</sup> is patented world-wide.

### References

1. Segev, A. "Mixing Effects on Water Dispersion in Crude Oil Flows" A.I.Ch.E. 1985 Spring Meeting, Houston, Texas.
2. Peerless, S.J. and Jiskoot, M.A. "Unique Pipeline Conditioning System - Interim Report". Sept 1978.
3. Pursley, W.C. and Humphreys, J.S. "Representative Sampling of Crude Oil/Water Mixtures" Automatic Sampling and Metering Conference, Maidstone, England, Nov. 1981
4. Hayward, A.T.J. and Jelffs, P.A.M. "Homogenisation by Jet Mixers with special reference to Tanker Discharge Pipelines" Automatic Sampling and Metering Conference, Maidstone, England, Nov., 1981.
5. B.P. Internal Report "Evaluation of Jet Mixing Systems" August 1982.
6. Walker, S.P. "Configuration Response of a Jet Mixer to Variations in Water Concentration: An Integral/Continuity Approach" Research Note, March 1985.
7. Jiskoot, J.S. "Automatic Sampling and Water Determination for Crude Oils", Automatic Sampling and Metering Conference, Maidstone, England, Nov., 1981.
8. American Petroleum Institute (API) Manual of Petroleum Measurement, Chapter 8, Section 2.

### Postscript

Over 100 Jet-Mix<sup>®</sup> systems have been installed for pipelines ranging in size from 3" to 48" and Jet-Mix<sup>®</sup> has also been used for blending applications where pressure losses have to be minimised and for injection of NGL into crude oils to prevent asphaltene precipitation. Over 60% of the world's crude oil supply sampled at major export and import terminals are mixed by the Jiskoot Jet-Mix<sup>®</sup>.



**UK**  
Jiskoot Quality Systems

Tel: +44 (0)1892 518000  
Fax: +44 (0)1892 518100

Email: ms-jiskootuksales@c-a-m.com

**USA**  
Jiskoot Quality Systems

Tel: +1 281 583 0583  
Fax: +1 281 583 0587

Email: ms-jiskootusasales@c-a-m.com

**Cameron**  
Measurement Systems

Tel: +1 281 582 9500  
Fax: +1 281 582 9599

Email: ms-marketing@c-a-m.com

Jiskoot Quality Systems  
A Cameron Company  
[www.jiskoot.com](http://www.jiskoot.com)



[www.c-a-m.com/flo](http://www.c-a-m.com/flo)