



In-Line Blending (Control Systems)

by Brian T. Ince

Introduction

In-line blending is the continuous mixing together of two or more different component streams in order to obtain a final product of closely defined proportions. It is often more economic than batch blending methods, saving money by blending faster, requiring less manpower and storage facilities. An in-line blending system can also be used to deliver the product directly into a pipeline or to road, rail or ocean going tankers.

Jiskoot pioneered process automation techniques and by taking advantage of the advances made in electronic design is able to produce highly accurate blending control systems.

Basic Systems

In-line blending control systems can be divided into two categories:

- a) *Controlled Rate Systems*
- b) *Flow Responsive Systems*

The blend rate of a *controlled blending system* is governed by the demand flow rate set by the blend controller. This can be manually or automatically controlled and all component flows are maintained in the correct ratio, as a direct percentage of the total blend rate.

The blend rate of a flow responsive system is governed by the 'Main' or 'Wild' flow rate which is the main component stream to which all components and/or additive flows are ratioed.

Each of these systems has certain advantages. The flow responsive system is usually the cheaper,

however, variations and options are available which provide considerable overlap in control features and facilities of both methods.

The basic principle of operation of the Jiskoot 'controlled rate' blender is that the flow in each component line is measured by means of a flowmeter, and controlled (regulated) by means of either a control valve, or by varying the output from a positive displacement pump.

The meter may be a positive displacement meter fitted with a pulse transmitter; turbine meter fitted with pick up coils, vortex meter, electromagnetic flowmeter or 'Coriolis' mass meter. The signals from these meters would be scaled and totalised by the blender.

In-Line Blending (Control Systems)

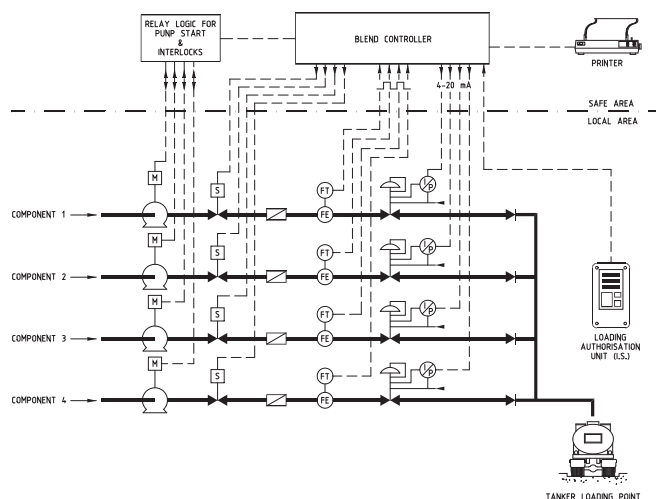

Controlled rate blender



Flow responsive blender

generates the demand flowrate for each component stream. The demand flowrate is equal to the total blender throughput multiplied by the required stream percentage. It follows, therefore, that by varying the master demand rate the total blend rate is increased or decreased without affecting the individual stream percentages.

The demand signal is fed to each stream controller PID algorithm as a set point and compared to the measured flow from the stream flowmeter. Any deviation between the set point and the measured flowrate is stored in memory and an appropriate adjustment is made automatically to the control valve in that stream. Thus opening or closing the valve to increase or decrease the component flow to bring this back to the required stream flowrate.

If there is starvation of flow in the metering stream, the control valve will open to compensate, but if it reaches a point at which it can no longer properly control, a cut-back (pacing) signal reduces the demand rate to equal the maximum flowrate at which the lagging component can maintain correct ratio and accuracy, and flags an alarm. If, however, when the rate reduces below the minimum blend rate, the blockage in the lagging component is still so great that control cannot be regained, a signal will be automatically produced which shuts down the blender, and flags an alarm. The amount of the lagging component that is missing is stored in the controller memory, and on re-starting the blender after the component flow restriction has been cleared, the component loss will quickly be made up and the blend will continue with no loss of accuracy.

Similarly, if the upstream pressure varies due to line size or tank head, the ability to reach the required or set flow rate is sometimes lacking, in such a case the system will “Cut back” the flow rate to ensure the product ratio is correct and alarm to alert the operator. The systems are so designed to allow “cutback” to continue until one of the streams reaches its low flow limit, at this point the blender will be shut down as accurate flow measurement is

not occurring.

In a flow responsive system it is the main or wild component stream which is used as the master and the other components or additives are ratioed to it, and are expressed as a percentage of the main/wild stream.

Control System Accuracy

As the whole system is digital and closed-loop, the accuracy of the electronics should be ± 1 pulse for the flow signal, and analogue conversion for temperature is around 1 part in 8000 for the 4-20mA range. The control system accuracy therefore is as good as the accuracy of the field equipment.

Since one pulse represents a very small quantity, the control system is continually calculating the so-called integral error between the required volume and the actual volume. This “error” is transmitted as a change to the control valve signal.

The accuracy of the whole system will depend entirely on the accuracy of the flow meter used. This means, therefore, that we can volumetrically blend components to within $\pm 0.5\%$ of instantaneous flow rate.

It follows that if one knows the quality parameters of the base components and additives, one can produce a very good final product within very close quality parameters. Most blending systems, particularly those in the petrochemical industries, operate this way and produce very good results.

Analyser Feedback and Trim

There are occasions where the quality of the base components of a blend may vary and yet it is still required to produce a final product to close viscosity tolerances. The solution is really quite simple: we use an analyser in the final blend header and allowed the analyser signal a limited freedom to reset the volumetric ratio setting. Jiskoot has used feedback signals from density analysers, viscosity analysers RVP analysers & octane analysers.

It is important that consideration is given to the effect of analyser trim, and the possibilities of stream starvation to maintain quality. It is usual to allow only a small drift in quality adjustment before raising an alarm, this prevents the analyser controls from shutting the blender down completely due to a fault in the analyser.

This practice of “analyser feedback” is now a regular occurrence in many multistream applications and it works very well. However the specifications governing the sale of products are becoming much tighter and the product costs are so high that many more quality limits are introduced. For instance, fuel oil at one time was primarily sold on viscosity only. In many cases this involved a simple two component blender that

ratioed gas oil to fuel oil. Today viscosity is not the only parameter looked at, some or all of the following may also be controlled, sulphur content, pour point, density, viscosity or the cetane no. for diesel oil.

It follows that the production of fuel oil is no longer a simple two component blend. Indeed it may be a four or five component blend and here we have a slight problem. To adjust an accurate, volumetric flow proportioning device by means of a signal from an analyser does not present a problem. To do likewise with signals from two analysers may still be an acceptable solution, however, one can readily visualise the "pushing-pulling" which could occur if quality parameters were being adjusted which affected each other.

To cope with this problem a system known as a non-interactive blending was designed, non-interactive in the sense that the correction signals from the various analysers are employed in such a way that they do not interact with each other.

However this form of blending requires numerous analysers and a computer with the ability to handle numerous complex calculations (matrix inversion). We are able to offer suitable software packages to provide this facility together with 'Blend Optimisation'.

Computer Supervised Blending

This consists primarily of a basic multi-stream blending system. However, all information such as component percentages, totaliser, etc are interfaced with a computer, as also is all analyser data. The function of the computer is as follows:

The PC is not used as a blender, but as an interface between our controller which is capable of handling all the field inputs/outputs and specific software for blending, analyser trim, PID control of valves and valve/pump sequencing. In this solution a typical PC is used in addition to our dedicated controller. The PC also provides communication not only to the stream controllers but to other Plant computers or DCS and SCADA systems in the plant or office.

The above configuration allows the system to be totally distributed, the PC is used only for mass data storage and a means for a control room operator interface, the blend control is by stand alone self contained controller. This allows real time control and processing with the added advantage that should the communications link fail between the PC and the blender, the blending process will continue.

Equipment Selection

As can be realised the mechanical components of the system are virtually identical no matter which level of control system is chosen.

The design of the mechanical section requires certain

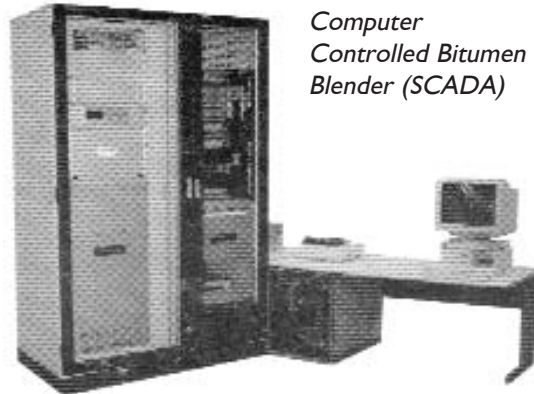

*Computer
Controlled Bitumen
Blender (SCADA)*

information to be made available. As a minimum this information should be:

- Expected overall system flowrate
- Number of components required to make product.
- Approximate ratios of each component.
- S.G. of each component.
- Viscosity of each component at normal blending temperature.
- Minimum and maximum temperatures and pressures of each component.
- Expected batch sizes.
- Number of recipes.
- Whether an analyser is required and which type.
- Whether hose connections are made or the inlets permanently piped.

To this end we can supply blender questionnaires to assist in obtaining the necessary information and to act as a reminder.

Jiskoot has in line blending plants installed over twenty years ago still in operation with the initial equipment, thus good engineering design coupled with correct equipment selection is imperative.

Field Equipment

The basic elements employed in each loop of a good in-line blending system are:

- a) A strainer of suitable mesh to prevent debris from damaging the downstream mechanical components. If air is likely to be present, getting in for example, when a hose exchange is used for product selection, or when the lines are purged after a blend to avoid cross contamination, an air eliminator should be used. A differential pressure switch or gauge should be fitted across the strainer basket to give an indication of blockage.
- b) A flow meter, accurate to $\pm 0.25\%$ over a 10 to 1 range. The flow meter type will depend upon each products characteristics such as viscosity and specific gravity. In general gasoline blenders use turbine meters, lubricating oil blenders use P.D. meters and fuel oil blenders use a combination of both P.D. and turbine meters. When turbine meters are used straightening vanes are required

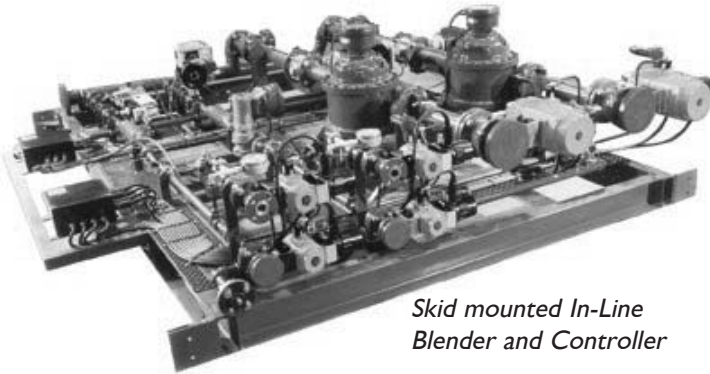

Skid mounted In-Line Blender and Controller

upstream of the meter to eliminate fluid swirl and velocity profile distortion. When P.D. meters are used a pulse transmitter is fitted to the output shaft to provide digital pulses proportional to volume.

- c) A control valve (either pneumatically or electrically operated) with valve positioner to control the rate of flow through the stream and maintain the correct proportions between streams. Control valve sizing is critical to the correct performance of the system. Alternatively a pump fitted with speed control is used, this is of particular benefit on small components with a high viscosity that require a P.D. pump.
- d) A non-return valve is fitted after the control valve to prevent back flow through the meters and subsequent contamination caused by pressure imbalances during start up/shut down.
- e) For systems requiring cleansing or purging after each batch a selection of vent and purge valves are fitted at strategic points to enable the stream to be blown forward to the blend header and backwards to the supply source.
- f) An analyser of some form suitable to measure the quality of the final product is often fitted in the blend header, on certain products mixing may well be required prior to analysing or final delivery. Mixers are available in various forms:

Static ie. a spool containing specially designed baffles which mix and mingle the product, these mixers use energy from the upstream pumping pressure thus will cause a pressure drop and are only efficient at certain flow rates.

Power, two major forms of power mixer are available, a blade type mixer connected to a motor; and Jet mixers which recycle a small volume of the product through an external pump and inject the product back into the line through specially designed jets to create mixing. Power mixers create insignificant pressure drops and work throughout the whole flow range of the system, the jet type has no moving parts inside the line and is relatively maintenance free.

- g) To maintain good control during temperature variations it is advisable to fit temperature transmitters to each stream, the signals from these are used by the control system to compensate the volume of liquid to standard conditions thus compensating for any effects of expansion or contraction of the liquid.

Current Trends

Whilst we have and can provide blenders for a range of liquids as diverse as beer, Molasses, LPG and lube oil, we have recently received several enquiries and orders for similar applications which may indicate a trend; these are as follows:

- Blending of various LPGs such as butane and propane to produce a range of aerosol propellant grades.
- Blending of various grades of ethanol with water and denaturants for the pharmaceutical, cosmetic and food industries.
- Blending of fuel oil with gas oil for ships bunkers, both static and trailer mounted on shore or mounted on the bunkering barge.
- Blending of various grades of bitumen and additives to produce a range of pen grade bitumens.
- Blending or injecting of dye into gas oil or kerosene for customs purposes.
- Blending or injecting of anti-static additives into aviation fuel, kerosene, and gas oil.

In conclusion, although there is no “black magic” to in-line blending, the design and control of the systems involved require careful and accurate calculations, and the persons involved should be technically aware of the many pitfalls surrounding such systems if the full benefits of installing an in-line blender are to be obtained.